

User manual ALFA(NET) 30 Thermometer.



VDH doc. 053806
Software: ALFA(NET) 30

Version: v1.1
File: Do053806.WPD

Date: 01-05-2006
Range: -50/+50°C

* Function.

The **ALFA(NET) 30** is a digital thermometer for panel mounting.
The **ALFANET 30** has a RS 485 network connection so it can be read out the Alfanet.

* Installation.

On the topside of the **ALFA(NET) 30** you can see how the sensor, power supply and relay has to be connected.
After connecting the **ALFA(NET) 30** to the power supply, a self test function is started. As this test is finished the measured temperature appears in the display.

* Control.

The **ALFA(NET) 30** thermostat has for normal use no need for controls. Only for adjustment of the sensor the ALFA 30 has three hidden pushbuttons on the front. These key are:

- SET** - view / change the setpoint.
- UP** - increase the setpoint.
- DOWN** - decrease the setpoint.

These pushbuttons are placed at the following places at the front:

- SET** - To the lower right of the display.
- UP** - To the upper left of the display.
- DOWN** - To the lower left of the display.

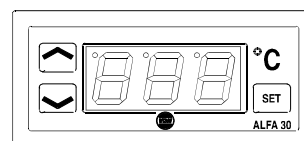

* **Setting internal parameter.**

To adjust the sensor-offset use the following instructions;

By pushing the **DOWN** key more than 10 seconds, you enter the 'internal programming menu'. In the left display the upper and lower segments are blinking. Over the **UP** and **DOWN** keys the required parameter can be selected (see table for the parameters). In this case only '04' offset temperature sensor.

If the required parameter is selected, the value can be read-out by pushing the **SET** key. Pushing the **UP** or **DOWN** keys together with the **SET** key allows you to change the value of this parameter. If no key is pushed for 20 seconds, the **ALFA(NET) 30** changes to its normal operation mode.

* **Adjustment sensor.**

The sensor can be adjusted by using the Sensor Offset (parameter 04). Indicates the **ALFA(NET) 30** e.g. 2°C too much, the Sensor Offset has to be decreased by 2°C.

* **Error messages.**

In the display of the **ALFA(NET) 30** the following error messages can appear:

- E1** - Sensor broken Solution:
 - Check if the sensor is connected correctly.
 - Check the sensor (1000Ω/25°C).
 - Replace the sensor.
- EE** - Settings are lost. Solution:
 - Reprogramme the settings.
- L-** - In case of sensor short-circuit the display alternates between error-code **E1** and **-L-**, as indication for a short-circuit sensor.
- H-** - In case of open-circuit sensor the display alternates between error-code **E1** and **-H-**, as indication for a open circuit sensor.

* **Technical details.**

Model	: ALFA(NET) 30
Range	: -50/+50°C, readout per 1°C (or else see product sticker)
Supply	: 230 Vac (or else see product sticker)
Communication	: RS 485 Network (2xtwisted pair shielded) only at ALFANET model.
Control	: by hidden pushbuttons on the front.
Front	: Polycarbonate IP65
Sensor	: SM 811 (1000Ω at 25°C) 2-wire.
Sizes	: 35 x 77 x 71,5mm (hwd)
Panel hole	: 28 x 70mm (hw)

- Provided with memory protection during power failure.
- Connection with screw terminals on the backside.
- Equipped with self test function and sensor failure detection.
- Special versions are available upon request.



* **Parameters ALFA(NET) 30 .**

PARA-METER	DESCRIPTION PARAMETER	RANGE	STANDARD VALUE
04	Offset temperature sensor	-15..+15°C	0
90	Network number	1..250	1
95	Software version	0..255	-
96	Production year	00..99	-
97	Production week	1..52	-
98	Serial number (x1000)	0..255	-
99	Serial number (units)	0..999	-

* **Dimensions.**

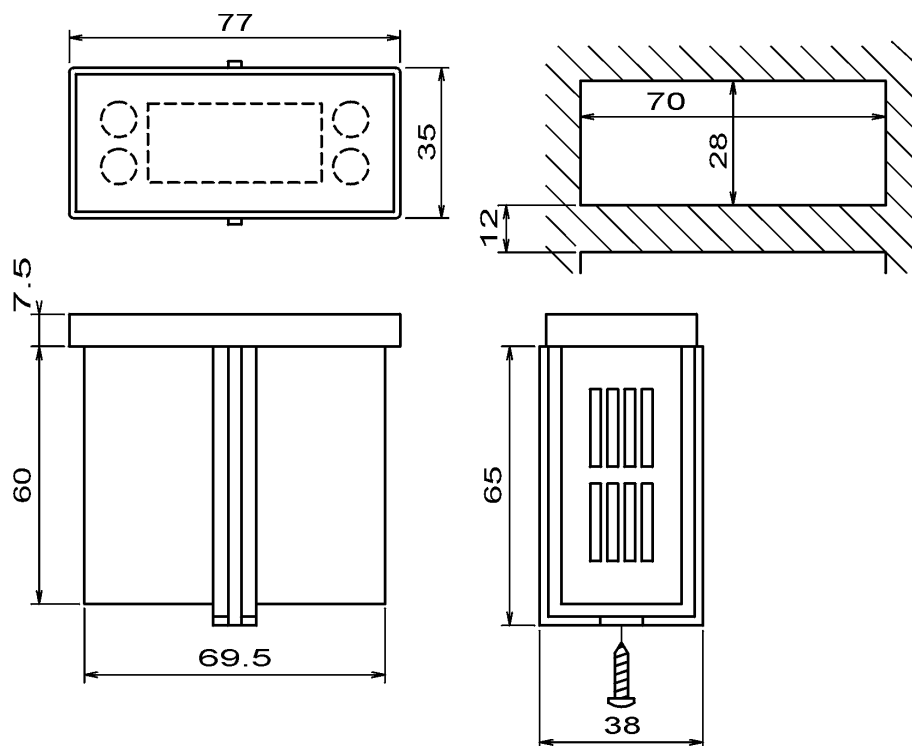

* **Connection diagram.**

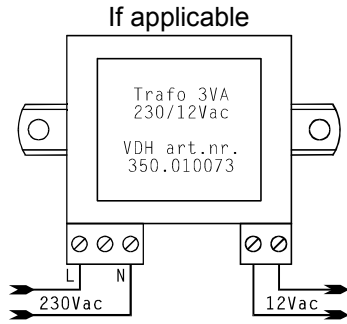

**ALFA(NET)
30-series**

*)REMARK: To terminate RS485-Network
Connect a 250 Ohm resistor between
Line-A and Line-B at both cable-ends

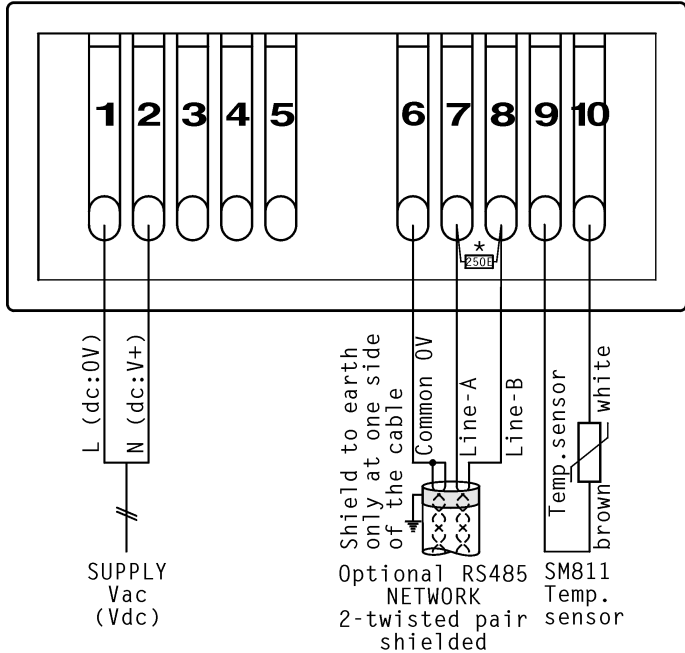

RS 485 NETWORK CONNECTIONS 2-twisted pair shielded cable:

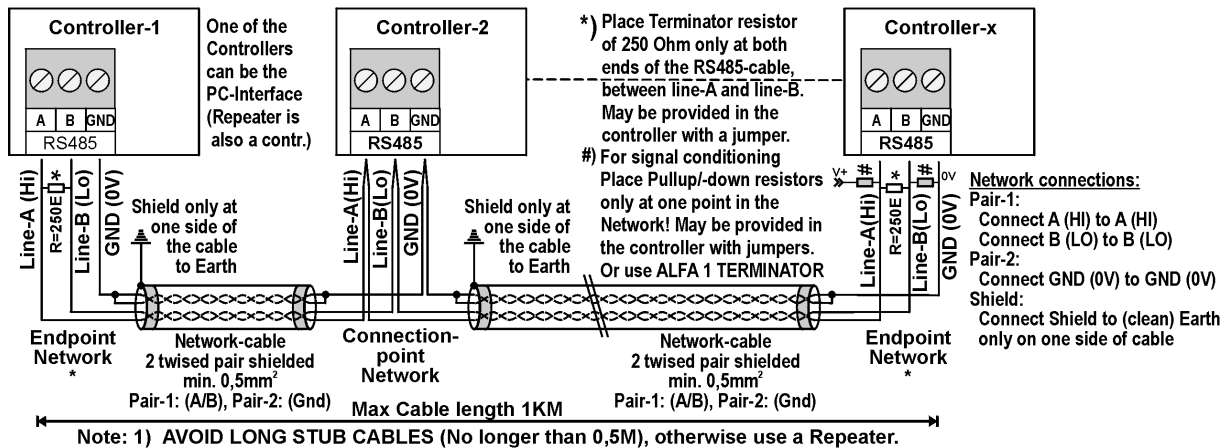

* **Address.**

VDH Products BV
 Produktieweg 1
 9301 ZS Roden
 The Netherlands

Tel: +31 (0)50 - 30 28 900
 Fax: +31 (0)50 - 30 28 980
 Email: info@vdhproducts.nl
 Internet: www.vdhproducts.nl

