

# User manual

## ALFANET 79

### Hygrostat.

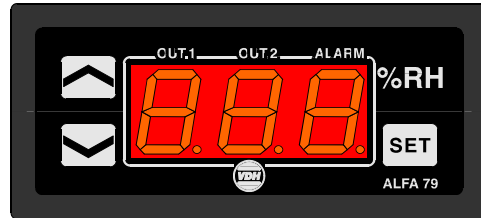

VDH doc: 010668

Version: v1.0

Datum:19-03-2001

Software: ALFA(NET)79

File: Do010668.WP8

Range: 0/+100%RH

#### \* Installation.

On the topside of the **ALFANET 79** is shown how the sensor, power supply and relays has to be connected.

After connecting the **ALFANET 79** to the power supply, a self test function is started. As this test is finished the measured humidity appears in the display.

And adjustable thru the **ALFANET PC-INTERFACE** on the PC.

#### \* Control.

The **ALFANET 79** Hygrostat can be controlled by four push buttons on the front. These keys are:

- SET** - view / change setpoint and reset alarm.
- UP** - increase value.
- DOWN** - decrease value.
- %RH** - hidden key above **SET** key and behind %RH symbol.

#### \* View setpoint.

By pushing the **SET** key the setpoint appears in the display. The decimal point of the last display starts blinking to indicate this. After a few seconds after releasing the **SET** key the setpoint disappears and the measured temperature is shown again.

#### \* Changing setpoint.

Push the **SET** key and the setpoint appears in the display. Release the **SET** key. Now push the **SET** key again together with the **UP** or **DOWN** keys to change the setpoint. After a few seconds after releasing the **SET** key the setpoint disappears and the measured temperature is shown again.

#### \* Status of the Relays.

By pushing the hidden °C key the display shows the status of the relays. Each display segment shows the status of the relay output, showing 0= off and 1=on. The code 110 means relay 1 and relay 2 are on and relay 3 is off.

#### \* Setting internal parameters.

Next to the adjustment of the setpoint, some internal settings are possible like differentials, sensor-adjustments, setpoint-range and function of the hygrostat.

By pushing the **DOWN** key for more than 10 seconds, you enter the 'internal program-ming menu'.

In the left display the upper and the lower segments are blinking. Over the **UP** and **DOWN** keys the required parameter can be selected (see table for the parameters).

If the required parameter is selected, the value can be read-out by pushing the **SET** key. Pushing the **UP** and **DOWN** keys allows you to change the value of this parameter.

If after 20 seconds no key is pushed, the **ALFANET 79** changes to it's normal operation mode.



\* **Sensor adjustment.**

The humidity-sensor can be adjusted by using the Offset Humidity sensor (parameter 05). Indicates the **ALFANET 79** e.g. 2% too much, than the Offset Humidity sensor (parameter 05) has to be decreased with 2%.

\* **Error messages.**

In the display of the **ALFANET 79** the following error messages can appear:

<b>rLO</b>	- Minimum RH alarm.	<u>Solution E1:</u>
<b>rHI</b>	- Maximum RH alarm.	- Check if sensor is connected correctly.
<b>E1</b>	- RH sensor failure.*	- Check RH-signal. (0/+100%RH=0/+1Vdc)
		- Replace sensor.
<b>EE</b>	- Settings are lost.	<u>Solution EE:</u>
		- Reprogram the settings.

\*)

- L**- - In case of sensor short-circuit the display alternates between error-code **E..** and **-L-**, as indication for a short-circuit sensor.
- H**- - In case of open-circuit sensor the display alternates between error-code **E..** and **-H-**, as indication for a open circuit sensor.

\* **Reset Alarm.**

When a error-messages appears it can be reset by pushing the **SET** key. The function of this key depends on parameter P37.

\* **Technical details.**

Type	: ALFANET 79 Hygrostat.
Range	: 0/+100%RH read-out per 1%RH
Read out	: 3-digit 7-segments display
Status LEDs	: LED 'SET' and LED 'RH'
Supply	: 12 Vac 50/60Hz (-5/+10%).
Relays	: Ry1= SPST(NO) 250V/8A (cos φ=1) of 250V/5A (cos φ=0.4) Ry2= SPST(NO) 250V/8A (cos φ=1) of 250V/5A (cos φ=0.4) Ry3= SPDT(NO/NC) 250V/8A (cos φ=1) of 250V/5A (cos φ=0.4) The three relays have one common (C).
Control	: Thru pushbuttons on front.
Front	: Polycarbonate.
Sensor	: RH 95-2 (+12Vdc; 0/+100%RH = 0/+1Vdc)
Communication	: RS485-Network (2-wire shielded min. 0,75mm <sup>2</sup> ; A, B and GND)
Dimensions	: 35 x 77 x 71,5mm (HWD).
Panel-cutout	: 29 x 71mm (HW).
Accuracy	: ± 0,5% of range.

- Provided with memory protection during power failure.
- Equipped with self-test function and sensor-failure detection.
- Connection with screw-terminals.
- Special version on request available.



\* **Parameters ALFANET 79**

Parameter	Description Parameter	Range	Default Value
01	Function Relays 1	1=Humidify 2=Dehumidify 3=Alarm	1
02	Function Relays 2	1=Humidify 2=Dehumidify 3=Alarm	2
03	Function Relays 3	1=Humidify 2=Dehumidify 3=Alarm	3
05	Offset Humidity sensor	-15...+15%RH	0
10	Switching differential relay 1	1..15%RH	1
11	Switching offset relay 1	-15...+15%RH	0
12	Switching differential relay 2	1..15%RH	1
13	Switching offset relay 2	-15...+15%RH	0
14	Switching differential relay 3	1..15%RH	1
15	Switching offset relay 3	-15...+15%RH	0
20	Minimum setpoint	0..100%RH	0
21	Maximum setpoint	0..100%RH	100
30	Alarm mode	0= None 1= Absolute 2= Relative	1
31	Minimum alarm setpoint	0..100%RH	0
32	Maximum alarm setpoint	0..100%RH	100
33	Time-delay minimum alarm	0..99 min.	0
34	Time-delay maximum alarm	0..99 min.	0
35	Function alarm relay	0= watchdog al. 1= regulated al.	0
36	Auto reset alarm after failure recovering	0= No 1= Yes	0
37	Manual reset alarm relay with set key	0= No 1= Yes	0
40	Control-delay after power failure	0..99 min.	0
41	Forced relay function at sensor failure	0= None 1= Humidify 2= Dehumidify	0
50	Time correction (at realtime clock)	-99...+99	0,00
90	Network number	1..31	1
95	Software version	0..255	0
96	Production year	00..99	0
97	Production week	1..52	1
98	Serial number (x1000)	0..255	0
99	Serial number (units)	0..999	0

(c) VDH Products BV



\* **Dimensions.**

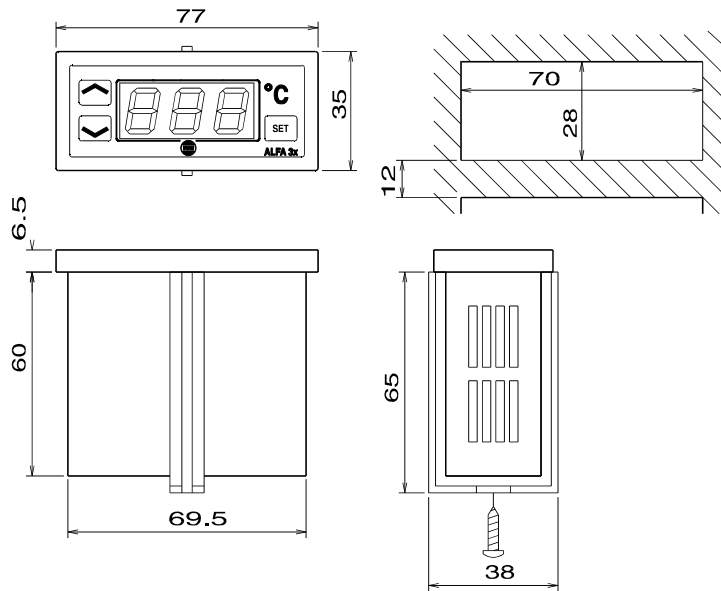

\* **Connections.**

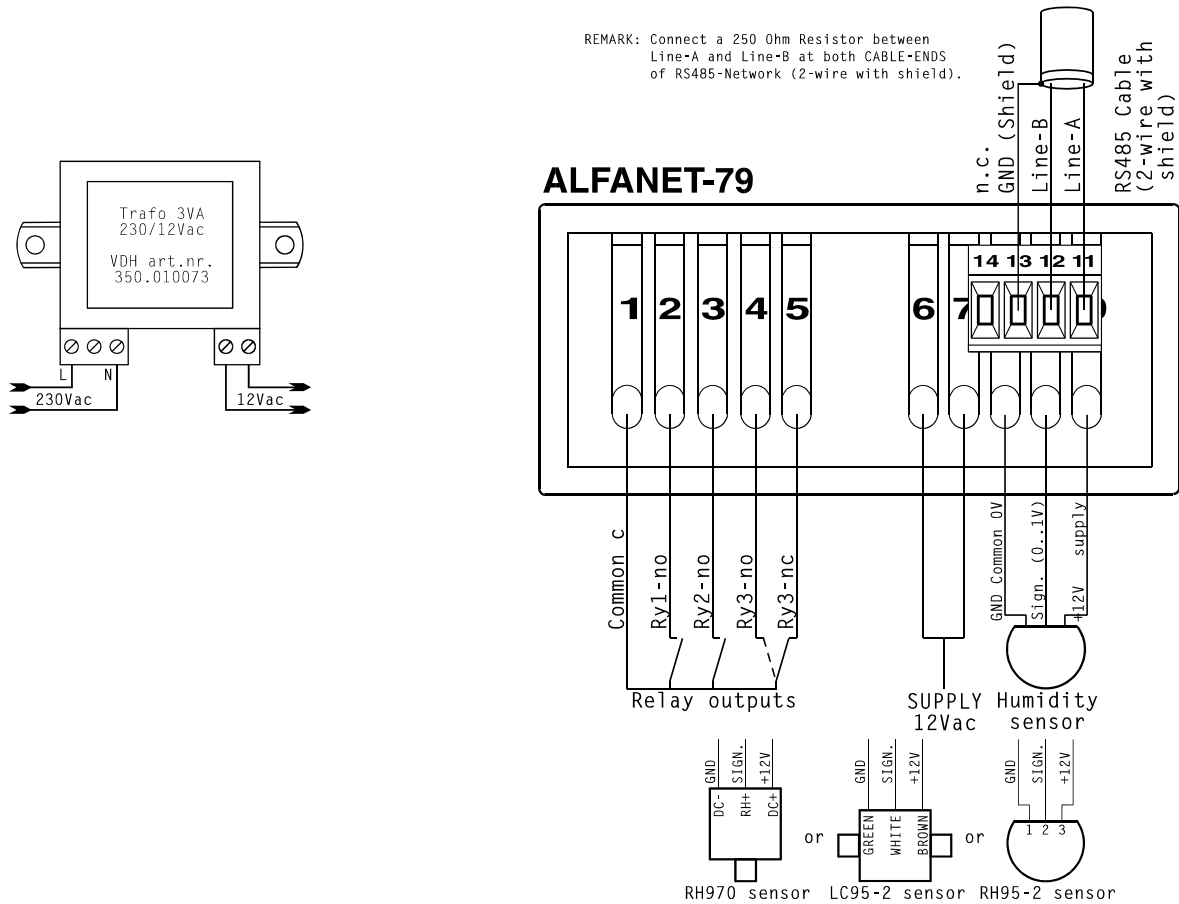

\* **Address.**

VDH Products BV  
 Produktieweg 1  
 9301 ZS Roden  
 The Netherlands

Tel: +31 (0)50 - 30 28 900  
 Fax: +31 (0)50 - 30 28 980  
 Email: info@vdhproducts.nl  
 Internet: www.vdhproducts.nl

